



PanBlast™ AbraFlo II NPT Abrasive Trap

The PanBlast™ AbraFlo II NPT Abrasive Trap is specifically designed in a cyclonic configuration to trap any abrasive particles which are exhausted from the pressure blast pot when depressurized.

This greatly reduces both the wear and tear on the Remote Control exhaust valve and exhaust muffler, and also reduces the risk of injury from airborne abrasive particles from the pressure blast pot depressurization.

Incorporating a lower storage hopper with a quick release drain out port ensures that larger and oversize abrasive particles are captured and stored below the abrasive trap screen and are able to be discharged with ease.

Periodic cleaning of the abrasive screen is also simplified via a blown down valve fitted on the lower valve chamber for reverse air flow purging of particles and debris without the need of dismantling and resulting in extended screen life.

A simple quick release top cap arrangement provides for quick change outs of the abrasive screens and for general maintenance inspection.



PanBlast™ AbraFlo II NPT Abrasive Trap Assembly -

Stock Code	Description	Weight
BAC-VA-0353-00	AbraFlo Abrasive Trap II Assembly	1.70Kg (3.75lbs)

PanBlast™ AbraFlo II NPT Abrasive Trap Part Listing -

Item	Stock Code	Description	Qty
1	YAC-FN-0351-00	Screw Machine Hex HD 1/4"UNC x 3/4" L(ZP)	3
2	YAC-FN-PB-0118	Washer Spring 1/4"	3
3	YAC-FN-0305-00	Washer Flat 1/4"	3
4	YAC-VA-0373-00	AbraFlo Trap II - Cap	1
5	YAC-BS-PB-0029	O-Ring ID39.5mm x Dia 3.53mm	1
6	YAC-VA-PB-0185	AbraFlo Trap - Rubber Pad	1
7	BAC-VA-0345-00	Abrasive Trap Screen	1
8	YAC-VA-0374-00	AbraFlo Trap II - Screen Gasket	1
9	YAC-VA-0354-00	AbraFlo Trap II - Body	1
10	YAC-VA-PB-0183	AbraFlo Trap - Thread Sleeve	2
11	YAC-PF-0315-00	Hex Cap 1/2" NPT (SS)	1
12	YAC-PF-PB-0243	Hex Nipple 1/4" NPT (ZP)	1
13	YAC-PF-0316-00	Elbow F & F - 1/4" NPT (SS)	1
14	YAC-PF-PB-0167	Mini Ball Valve 1/4" BSP M x F Handle To F	1
15	YAC-PF-PB-0242	Hex Plug 1/4" NPT (BP)	1

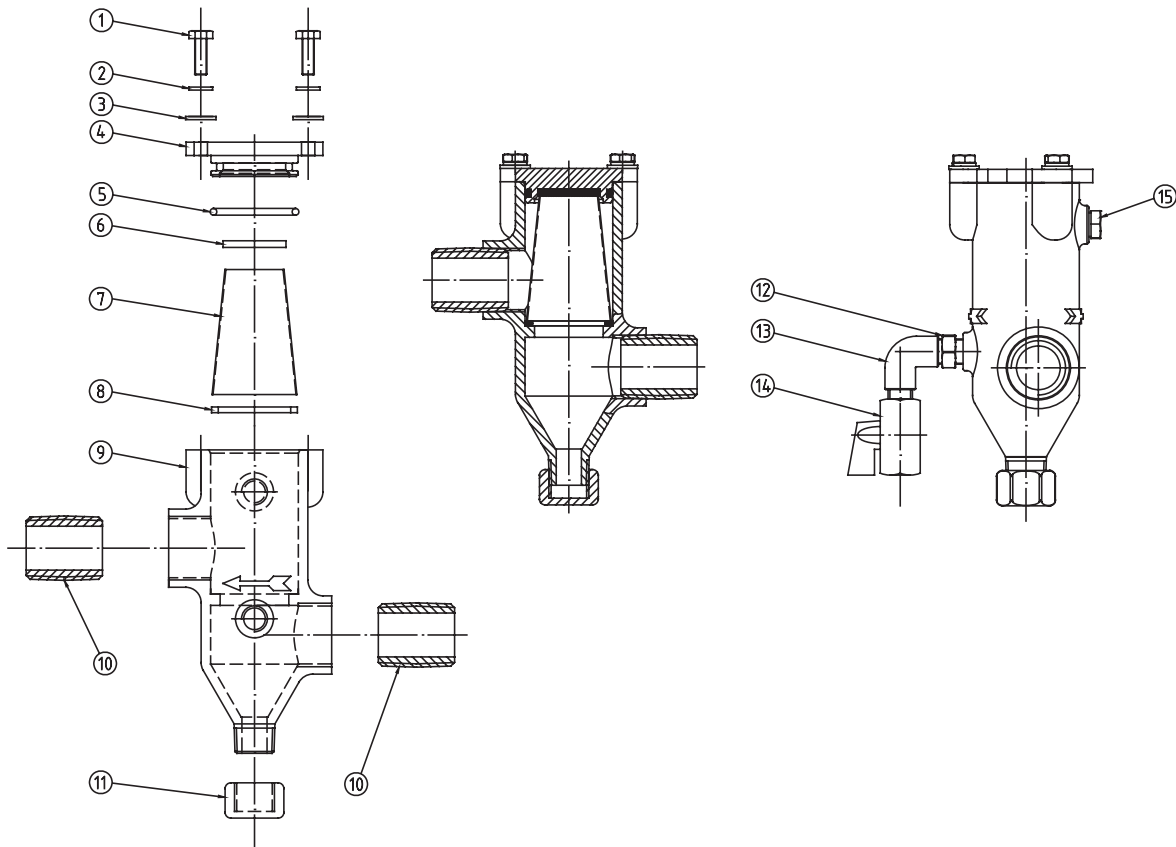

Blast Pots & Cabinets - Remote Control Valves - Abrasive Control Valves - Blast Nozzles - Nozzle Holders & Couplings - Helmets & Breathing Air Filters - Blast Suits