



PanBlast™ ConeBlast 1/2" Internal Pipe Blasting Tool

*"Surface Preparation
Is Our Business"*

The PanBlast™ ConeBlast 1/2" Internal Pipe Blasting Tool is designed to blast the inside surface area of pipes, in sizes ranging from 50mm (2") to 305mm (12") internal diameter.

The ConeBlast tools feature a built in short venturi nozzle system, combined with a tungsten carbide deflection tip, which deflects the abrasive into a 360° blast pattern as it exists the end of the ConeBlast assembly.

The PanBlast™ ConeBlast devices are available in two (2) sizes, ConeBlast 1/4" and ConeBlast 1/2".

The ConeBlast 1/2" unit comes complete with a set of centring collars to centre the tool within the pipe.

A fully adjustable centring carriage is also available as an optional for the ConeBlast 1/2" unit, which is used for pipe diameters between 125mm (5") and 305mm (12").

The wearing parts, such as the deflection tip, stem sleeves and stem support assembly are constructed from tungsten carbide for maximum operating life.

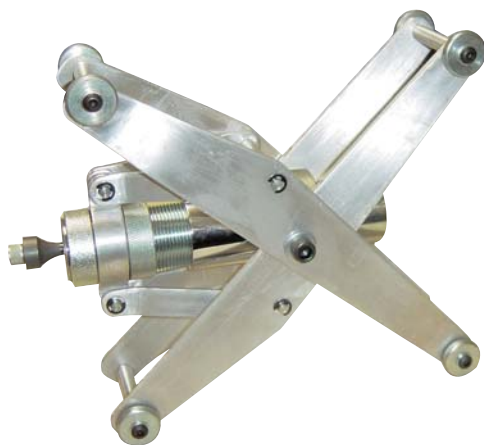

ConeBlast 1/2" Assembly
Shown Fitted in Optional
Centring Carriage

ConeBlast 1/2"	
Minimum Pipe Diameter	50mm (2")
Maximum Pipe Diameter Using Centring Collars	125mm (5")
Maximum Pipe Diameter Using Centring Carriage	305mm (12")
Compressed Air Requirement	340m ³ /hr (200cfm)



Blast Pots & Cabinets - Remote Control Valves - Abrasive Control Valves - Blast Nozzles - Nozzle Holders & Couplings - Helmets & Breathing Air Filters

PanBlast™ ConeBlast 1/2" Assembly -

Item	Stock Code	Description	Weight
17	BAC-BA-PB-0094	Coneblast 1/2" Tool Assembly Only	1.65kg (3.63lbs)
18	BAC-BA-PB-0001	Coneblast 1/2" Tool, Collar & Button Assembly	3.13kg (6.89lbs)
19	BAC-BA-PB-0021	Coneblast 1/2" Centering Carriage	1.85kg (4.07lbs)

PanBlast™ ConeBlast 1/2" Parts List -

Item	Stock Code	Description	Qty
1	YAC-BA-PB-0002	Tip Protection Sleeve	1
2	YAC-BA-PB-0003	Knurled Lock Nut	1
3	BAC-BA-PB-0004	1/2" Tungsten Carbide Nozzle	1
4	BAC-BA-PB-0095	Stem Support & Throat Rod Assembly	1
5	YAC-BA-PB-0006	Deflector Pin Holder	1
6	YAC-BA-PB-0007	Connecting Tube	1
7	YAC-BA-PB-0008	Tip Holding Nut	1
8	YAC-BA-PB-0009	Tungsten Carbide Deflector Tip	1
9	YAC-BA-PB-0010	Stem Extension Sleeve	1
10	YAC-BA-PB-0011	Throat Sleeve	1
11	YAC-FN-PB-0177	Flat Washer	3
12	YAC-BS-PB-0005	O-Ring	1
13	YAC-BA-PB-0017	Flat Washer	1
14	YAC-BA-PB-0018	Flat Washer	2
15	BAC-BA-PB-0066	Coneblast Button 3-1/2" to 5" Full Set	1
16	BAC-BA-PB-0073	Full Collar Set	1

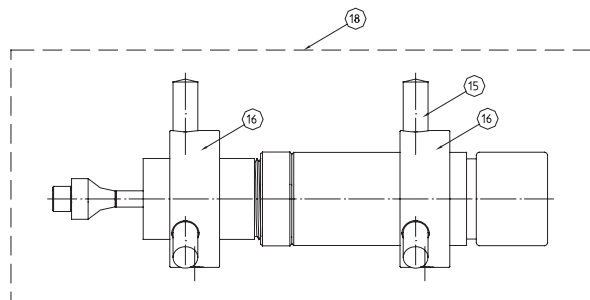
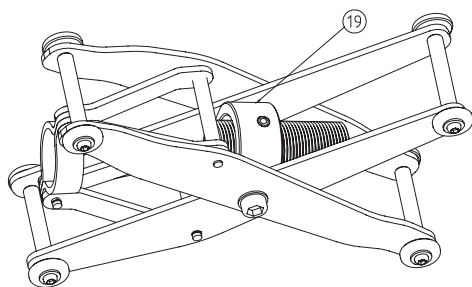
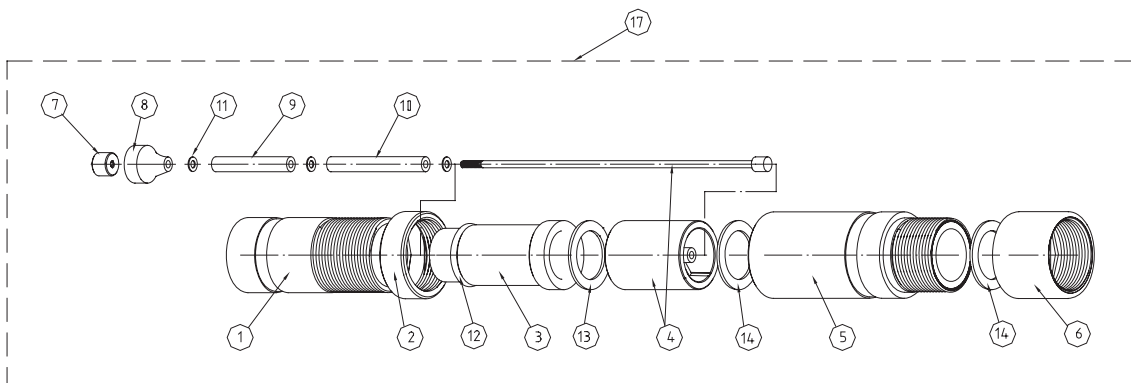

Blast Pots & Cabinets - Remote Control Valves - Abrasive Control Valves - Blast Nozzles - Nozzle Holders & Couplings - Helmets & Breathing Air Filters - Blast Suits