



PanBlast™ Helix 50 BSP Exhaust Control Valve

*"Surface Preparation
Is Our Business"*

PanBlast™ Helix 50 BSP Exhaust Control Valve

The PanBlast™ Helix 50 BSP Exhaust Control Valve is a diaphragm operated air control valve which is used to exhaust the compressed air from the blast pot and is designed to be used in conjunction with the PanBlast™ Helix 100 BSP Inlet Control Valve (or similar).

The PanBlast™ Helix 50 BSP Exhaust Valve is designed to provide fast and effective operation, as soon as it receives a signal from the operators deadman control handle and both the valve itself, as well as all its parts, are fully compatible with the OEM RMS style valve.

Powder coated outer surfaces, along with anodized internal parts, mean that the PanBlast™ Helix 50 BSP Exhaust Control Valve has a very high resistance to corrosion.

Featuring 19mm (3/4") ports, the PanBlast™ Helix 50 BSP Exhaust Control Valve may also be combined with the PanBlast™ Helix 100 BSP Inlet Control Valve, to create the Helix 150 BSP Remote Control Valve, which is a combined inlet and exhaust valve in the one compact assembly.



Helix 50 BSP Exhaust Control Valve



Helix 150 BSP Combination Inlet
And Exhaust Valve

PanBlast™ Helix 50 BSP Exhaust Control Valve Assembly -

Stock Code	Description	Weight
BAC-RC-PB-0306	Helix 50 BSP Exhaust Valve Assembly	2.43kg (5.35lbs)

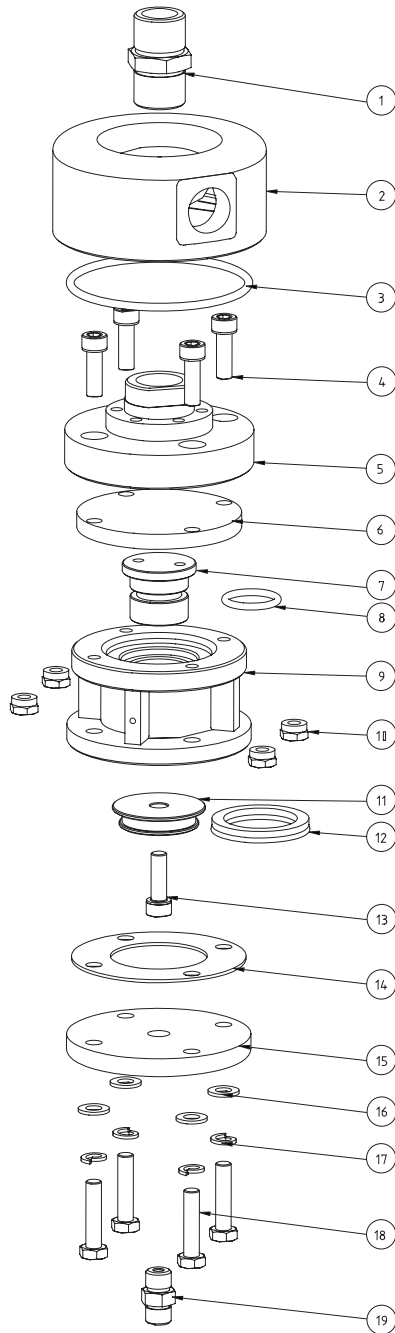

PanBlast™ Helix 50 BSP Exhaust Valve Parts List -

Item	Stock Code	Description	Qty
1	YAC-PF-PB-0052	Hex Nipple	1
2	YAC-RC-PB-0333	Exhaust Manifold	1
3	YAC-BS-PB-0048	O-Ring	1
4	YAC-FN-PB-0278	Socket Head Screw	4
5	YAC-RC-PB-0331	Exhaust Base	1
6	YAC-RC-PB-0330	Diaphragm	1
7	YAC-RC-PB-0328	Outlet Piston	1
8	YAC-BS-PB-0047	O-Ring	1
9	YAC-RC-PB-0326	Valve Body	1
10	YAC-FN-PB-0198	Nylon Lock Nut	4
11	YAC-RC-PB-0324	Piston	1
12	YAC-RC-PB-0325	U Seal	1
13	YAC-FN-PB-0280	Socket Head Screw	1
14	YAC-RC-PB-0319	Cap Gasket	1
15	YAC-RC-PB-0317	Cap	1
16	YAC-FN-PB-0022	Flat Washer	4
17	YAC-FN-PB-0021	Spring Washer	4
18	YAC-FN-PB-0197	Hex Head Machine Screw	4
19	YAC-PF-PB-0041	Hex Nipple	1

PanBlast™ Helix 50 BSP Exhaust Valve Service Kits -

Stock Code	Description
BAC-RC-0476-00	Helix 50 BSP Valve Seal Kit - Includes items 3, 6, 8, 12 & 14

