



PanBlast™ Helix 50 NPT Exhaust Control Valve

*“Surface Preparation
Is Our Business”*

PanBlast™ Helix 50 NPT Exhaust Control Valve

The PanBlast™ Helix 50 NPT Exhaust Control Valve is a diaphragm operated air control valve which is used to exhaust the compressed air from the blast pot and is designed to be used in conjunction with the PanBlast™ Helix 100 NPT Inlet Control Valve (or similar).

The PanBlast™ Helix 50 NPT Exhaust Valve is designed to provide fast and effective operation, as soon as it receives a signal from the operators' deadman control handle. Both the valve itself, as well as all its parts are fully compatible with the OEM RMS style valve.

Powder coated outer surfaces, along with anodized internal parts, mean that the PanBlast™ Helix 50 NPT Exhaust Control Valve has a very high resistance to corrosion.

Featuring 19mm (3/4") ports, the PanBlast™ Helix 50 NPT Exhaust Control Valve may also be combined with the PanBlast™ Helix 100 NPT Inlet Control Valve, to create the Helix 150 NPT Remote Control Valve, which is a combined inlet and exhaust valve in the one compact assembly.



Helix 50 NPT Exhaust Control Valve



Helix 150 NPT Combination Inlet
And Exhaust Valve

PanBlast™ Helix 50 NPT Exhaust Control Valve Assembly -

Stock Code	Description	Weight
BAC-RC-PB-0310	Helix 50 NPT Exhaust Valve Assembly	2.13kg (4.69lbs)

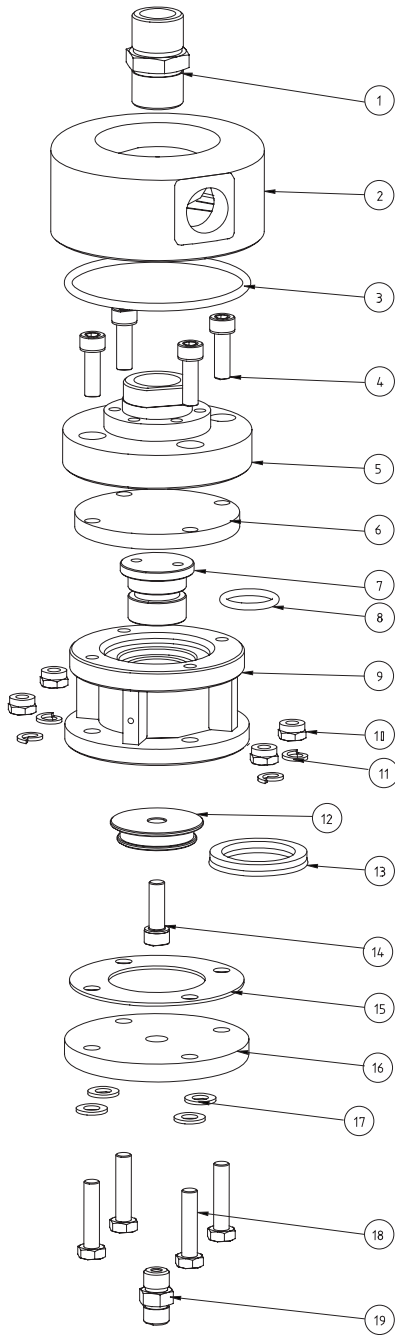

PanBlast™ Helix 50 NPT Exhaust Valve Parts List -

Item	Stock Code	Description	Qty
1	YAC-PF-PB-0244	Hex Nipple	1
2	YAC-RC-PB-0334	Exhaust Manifold	1
3	YAC-BS-PB-0048	O-Ring	1
4	YAC-FN-PB-0279	Cap Head Machine Screw	4
5	YAC-RC-PB-0332	Exhaust Base	1
6	YAC-RC-PB-0330	Diaphragm	1
7	YAC-RC-PB-0329	Outlet Piston	1
8	YAC-BS-PB-0047	O-Ring	1
9	YAC-RC-PB-0327	Valve Exhaust Cylinder	1
10	YAC-FN-PB-0283	Nut Lock Unc (ZP)	4
11	YAC-FN-PB-0021	Spring Washer	4
12	YAC-RC-PB-0324	Piston	1
13	YAC-RC-PB-0325	Piston U Seal	1
14	YAC-FN-PB-0281	Cap Head Machine Screw	1
15	YAC-RC-PB-0319	Cap Gasket	1
16	YAC-RC-PB-0318	Cap	1
17	YAC-FN-PB-0022	Flat Washer	4
18	YAC-FN-PB-0282	Hex Head Machine Screw	4
19	YAC-PF-PB-0243	Hex Nipple	1

PanBlast™ Helix 50 NPT Exhaust Valve Service Kits -

Stock Code	Description
BAC-RC-0476-00	Helix 50 NPT Valve Seal Kit - Includes items 3, 6, 8, 13 & 15

