



PanBlast™ SideWinder Angle Blast Nozzles

*"Surface Preparation
Is Our Business"*

The PanBlast™ SideWinder Angle Nozzles are designed for blasting areas that would normally be inaccessible with conventional blast nozzles.

The outlet(s) of the PanBlast™ SideWinder nozzles are located on the side of the nozzle, rather than the end, at an angle of 45°. This permits blasting in areas such as pipe internals, behind ledges and the flanges of beams and inside cavities.

The SideWinder Angle Blast Nozzles are available in various sizes and configurations, including 1 or 3 outlets and with nozzle diameters #4 (1/4" or 6 mm), #5 (5/16" or 8 mm) and #6 (3/8" or 10 mm). This allows the operator to select a SideWinder nozzle to suit almost any application and compressed air supply.

The SideWinder nozzle insert is constructed from long wearing tungsten carbide, mounted inside a tough aluminium outer jacket.

All PanBlast™ SideWinder Angle Blast Nozzles are available in both 50mm (2") contractor style thread and 1 1/4" NPSM threads.



PanBlast™ SideWinder 50mm (2") Coarse Thread Angle Blast Nozzles -

Stock Code	Description	Orifice Size		Thread Size		Entry Size		No. of Outlets	Blast Angle
		mm	in	mm	in	mm	in		
BAC-NZ-PB-0291	SideWinder 4 x 1	6mm	1/4"	50mm	2"	25mm	1"	1	45°
BAC-NZ-PB-0292	SideWinder 4 x 3	6mm	1/4"					3	
BAC-NZ-PB-0293	SideWinder 5 x 1	8mm	5/16"					1	
BAC-NZ-PB-0294	SideWinder 5 x 3	8mm	5/16"					3	
BAC-NZ-PB-0295	SideWinder 6 x 1	10mm	3/8"					1	
BAC-NZ-PB-0296	SideWinder 6 x 3	10mm	3/8"					3	

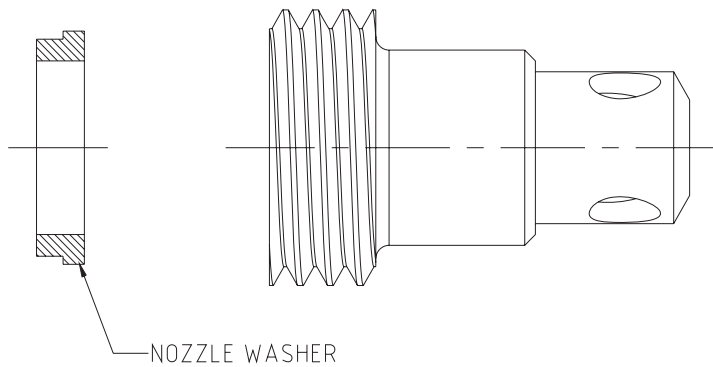

PanBlast™ SideWinder 1 1/4" NPSM Thread Angle Blast Nozzles -

Stock Code	Description	Orifice Size		Thread Size		Entry Size		No. of Outlets	Blast Angle
		mm	in	mm	in	mm	in		
BAC-NZ-PB-0299	SideWinder 4 x 1	6mm	1/4"	32mm	1 1/4"	25mm	1"	1	45°
BAC-NZ-PB-0300	SideWinder 4 x 3	6mm	1/4"					3	
BAC-NZ-PB-0301	SideWinder 5 x 1	8mm	5/16"					1	
BAC-NZ-PB-0302	SideWinder 5 x 3	8mm	5/16"					3	
BAC-NZ-PB-0303	SideWinder 6 x 1	10mm	3/8"					1	
BAC-NZ-PB-0304	SideWinder 6 x 3	10mm	3/8"					3	

Note: All blast nozzles are supplied with one (1) nozzle washer to suit NNH nylon nozzle holder.