

# PanBlast™ Corsa NPT Abrasive Control Valve - Tungsten Sleeve Type

*"Surface Preparation Is Our Business"*

## *PanBlast™ Corsa NPT Abrasive Control Valve*

The PanBlast™ Corsa NPT Abrasive Control Valve is a well-established first generation "industry standard" automatic on/off plunger type valve.

### *PanBlast™ Corsa NPT Valve Design Features:*

- Increased spring force for quicker valve actuation, which improves sleeve and seat service life.
- Lip plunger seal arrangement to ensure precise sealing and extended seal service life.
- Breather hole re-located and exhaust filter added to prevent dust from entering air chamber.
- Hexagon cast into valve top for easier assembly and disassembly.
- Connecting nipple carburise hardened to 55HRC, which greatly reduced wear.
- Improved plunger carbide sleeve using mechanical fixturing for greater reliability and extended service life of the feed orifice.
- Plunger seat design improved to provide better sealing and operating life.
- Improved piston design for smoother operation and better reliability.
- Available in North American NPT thread version, with either 1¼" or 1½" threads.
- Plunger, seat holder, bush and plunger cap now feature stainless steel construction.



The PanBlast™ Corsa NPT Valve is a normally closed abrasive metering valve requiring a pilot compressed air signal to open it, which then permits abrasive flow. The Corsa NPT Valve may be used on both pressure hold and pressure release blast pots.

When used on pressure hold, multiple outlet pots, the Corsa NPT Valve permits each operator to blast totally independent of each other. When used with pressure release blast pots, the Corsa NPT Valve prevents the blast hose filling with abrasive each time the pot is depressurized.

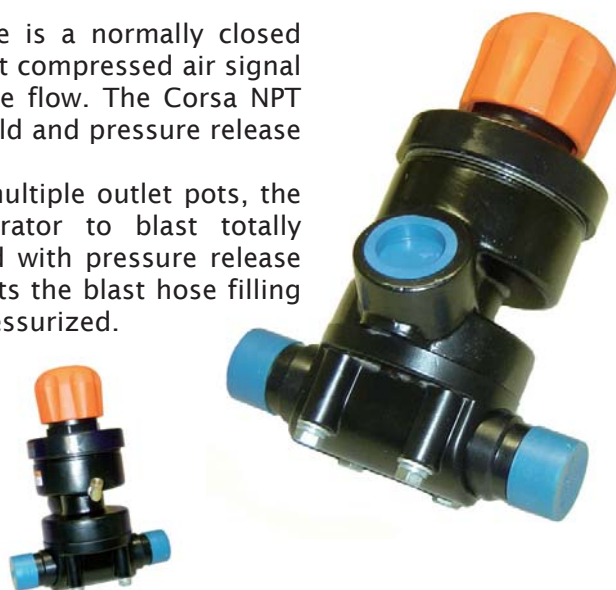

## PanBlast™ Corsa NPT Valve Assemblies -

Stock Code	Description	Weight
BAC-VA-PB-0165	Corsa II Valve complete with 1 1/4" M x 1 1/4" M Pipe Nipple (Item 22)	6.13kg (13.49lbs)
BAC-VA-PB-0163	Corsa II Valve complete with 1 1/2" M x 1 1/2" M Pipe Nipple (Item 23)	6.08kg (13.38lbs)

## PanBlast™ Corsa NPT Valve Parts List -

Item	Stock Code	Description	Qty
1	BAC-VA-PB-0154	Top	1
2	YAC-VA-PB-0095	Anti-Vibration Washer	1
3	YAC-VA-PB-0094	Stop Ring	1
4	YAC-VA-PB-0096	Spring	1
5	YAC-VA-PB-0097	Piston Seal	1
6	YAC-FN-0298-00	Nut 1/2" UNC (ZP)	1
7	YAC-VA-PB-0155	Piston	1
8	BAC-VA-PB-0219	Tungsten Carbide Plunger	1
9	BAC-VA-PB-0157	NPT Valve - Cylinder	1
10	YAC-VA-PB-0052	Plunger Seal	1
11	YAC-BS-PB-0032	O-Ring	1
12	BAC-VA-PB-0102	Tungsten Carbide Sleeve	1
13	YAC-VA-PB-0103	Urethane Seat	1
14	YAC-VA-PB-0104	Seat Holder	1
15	YAC-BS-PB-0034	O-Ring	1
16	YAC-VA-PB-0160	Base	1
17	YAC-FN-PB-0258	Flat Washer	4
18	YAC-FN-PB-0104	Hex Head Bolt	4
19	BAC-AF-PB-0163	Exhaust Filter	1
20	YAC-PF-PB-0234	Elbow c/w Nut	1
21	BAC-VA-PB-0168	Control Knob	1
22	BAC-VA-PB-0128	1 1/4" x 1 1/4" Pipe Nipple (Use with BAC-VA-PB-0165)	1
23	BAC-VA-PB-0129	1 1/2" x 1 1/2" Pipe Nipple (Use with BAC-VA-PB-0163)	1

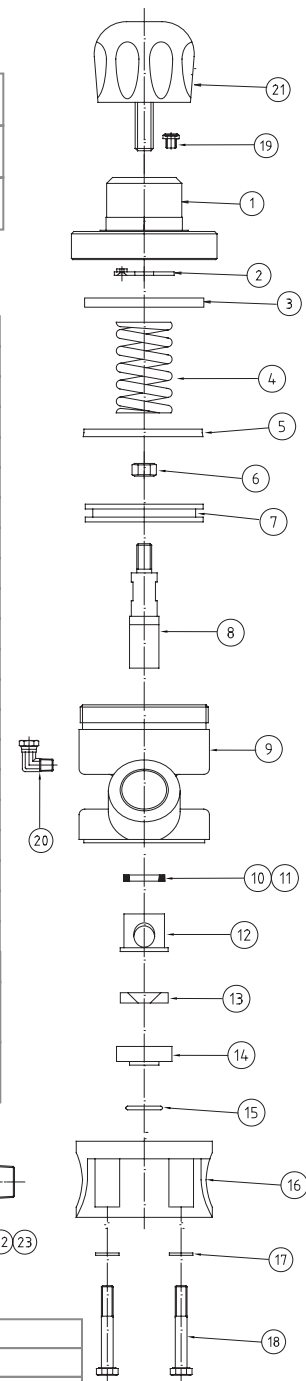

## PanBlast™ Corsa NPT Valve Service Kits -

Stock Code	Description
BAC-VA-PB-0028	Corsa NPT Valve Tungsten Seat Kit - Includes items 13, 14 & 15
BAC-VA-PB-0188	Corsa NPT Valve Upper Seal Kit - Includes items 5, 10, 11, 13 & 15
BAC-VA-PB-0029	Corsa NPT Valve Piston Kit - Includes items 2, 3, 4, 5, 6 & 7
BAC-VA-PB-0211	Corsa NPT Valve Base Kit - Includes items 16, 17 & 18
BAC-VA-PB-0167	Corsa NPT Valve Service Kit - Includes items 5, 8, 10, 11, 12, 13, 14 & 15

The Corsa NPT Valve may also be fitted with an abrasive cut off switch to stop abrasive flow, but still permit air flow to the blast nozzle, to create a blow down function. A plunger and orifice sleeve assembly meters the abrasive flow to the blast nozzle. Abrasive flow adjustment is via a metering knob that adjusts the depth of the plunger travel within the orifice sleeve. The standard sleeve is manufactured from wear resistant urethane, and an optional tungsten carbide sleeve and seat arrangement is also available for applications involving high wear rates.

Blast Pots & Cabinets - Remote Control Valves - Abrasive Control Valves - Blast Nozzles - Nozzle Holders & Couplings - Helmets & Breathing Air Filters - Blast Suits