



# PanBlast™ Tornado Internal Pipe Blasting Carriage Sets

*"Surface Preparation  
Is Our Business"*

## **PanBlast™ Tornado Internal Pipe Blasting Carriage Sets**

The PanBlast™ Tornado Internal Pipe Blasting Carriage Sets allow for optional carriages to be selected for various internal diameter pipe blasting applications. When combined with the PanBlast™ Tornado Internal Pipe Blasting Tool the system provides for a complete integrated and dependable internal pipe blasting solution.

### **PanBlast™ Tornado Internal Pipe Blasting Carriage Sets Feature:**

- \* All carriage sets are fully adjustable to meet the required internal pipe diameters and allow for central tool positioning and optimum blasting coverage.
- \* Interchangeable PanBlast™ ATN-S Series Blast Nozzles as standard supply with all Tornado Spin Blast Tools or (optional) PanBlast™ ATN-T Series Blast Nozzles ensuring that the Tornado Rotating Blast Head is positioned at the optimum distance to maximize blasting performance.
- \* In conjunction with the Tornado Large Range Carriage Set an Optional Large Rotating Blast Head is available, outfitted with 50mm (2") contractor threads allowing the use of long series UTN full venturi Blast Nozzles.

### **PanBlast™ Tornado Internal Pipe Blasting Carriage Sets Available Size Range:**

- \* PanBlast™ Small Range Scissor Carriage Set, when combined with the PanBlast™ Tornado Spin Blast Tool (BAC-BA-0170-00) caters for internal pipe diameters ranging between 8" to 17" (203mm to 431mm).
- \* PanBlast™ Mid Range Carriage Set, when combined with the PanBlast™ Tornado Spin Blast Tool (BAC-BA-0170-00) caters for internal pipe diameters ranging between 12" to 36" (304mm to 914mm).
- \* PanBlast™ Large Range Carriage Set, when combined with the PanBlast™ Tornado Spin Blast Tool (BAC-BA-0170-00) and the optional Large Rotating Head (BAC-BA-0206-00) caters for internal pipe diameters ranging between 40" to 60" (1016mm to 1524mm).



## PanBlast™ Tornado Internal Pipe Blasting Carriage Set Assemblies

Stock Code	Description	Weight
BAC-BA-0151-00	Tornado Small Range Scissor Carriage (Item 6)	3.15Kg (7.00lbs)
BAC-BA-0164-00	Tornado Internal Pipe Blaster-Mid Range Carriage Set (Items 1, 2, 4 & 5)	9.10Kg (20.00lbs)
BAC-BA-0165-00	Tornado Internal Pipe Blaster-Large Range Carriage Set (Items 1, 3, 4 & 5)	9.60Kg (21.16lbs)

## PanBlast™ Tornado Internal Pipe Blasting Carriage Set Parts List

Item	Stock Code	Description	Qty
1	YAC-BA-0168-00	Tornado Mid/Large Range Carriage-Front Body	1
2	BAC-BA-0166-00	Tornado Mid Range Legs Kit	1 SET
3	BAC-BA-0167-00	Tornado Large Range Legs Kit	1 SET
4	YAC-BA-0169-00	Tornado Mid/Large Range Carriage-Rear Body	1
5	YAC-FN-PB-0225	Machine Screw Hex HD 5/16 UNC x 26mm ZP	10
6	BAC-BA-0151-00	Small Range Scissor Carriage	1

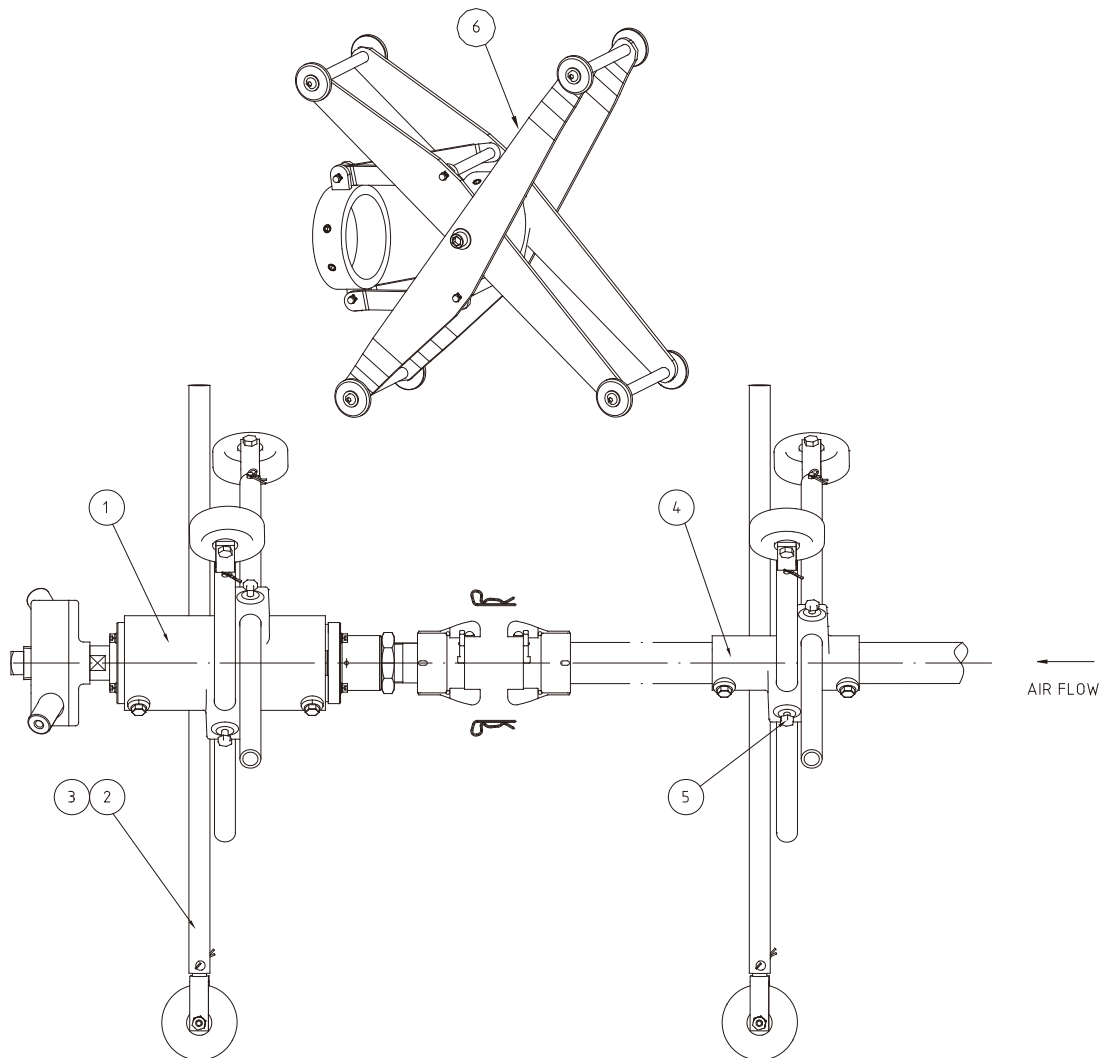

Blast Pots & Cabinets - Remote Control Valves - Abrasive Control Valves - Blast Nozzles - Nozzle Holders & Couplings - Helmets & Breathing Air Filters - Blast Suits