



PanBlast™ Soda Plus Max Package

The PanBlast™ Soda Plus Max combination package is ideally suited for contractors requiring high production volume and/or abrasive flow, and resellers servicing the soda blasting industry. Generic pressure blast machines can be retrofitted with the following leading edge PanBlast™ components:

- The PanBlast™ 1 1/2" (38mm) Corsa II Abrasive Metering Valve is a normally closed spring loaded automatic type abrasive metering valve requiring a compressed air pilot signal to activate, permitting precise metering of soda media. Standard features include:
 - Non-Corroding Stainless Steel internal valve components
 - Solid Tungsten Carbide Plunger
 - Quad Plunger Seal arrangement
 - 1" Clean Out Port
- The PanBlast™ 1 1/2" (38mm) Tandem Remote Control Valve is a rugged cast iron, pilot air operated, spring return diaphragm type valve. When fitted on pressure blast machines in conjunction with the PanBlast™ Corsa II Abrasive Metering Valve, the following machine operations are possible: air only blasting, air and water slurry blasting, or compressed air only blow down.
- The PanBlast™ AirStop II Remote Control Handle is a robust, pneumatically operated remote control handle that is ideal, when used with the above valve combinations, for soda blasting. The PanBlast™ AirStop II Remote Control Handle incorporates the industry's widest activation lever for greater operator comfort and control. The remote handle is failsafe, with a spring-loaded safety "lock out" mechanism to prevent accidental system activation.
- The PanBlast™ 1/2" (12.5mm) AIN Water Induction Nozzle features both user-adjustable water feed rate and venturi air injector ports for achieving optimum air/water atomization in the nozzle slurry. The PanBlast™ AIN Induction Nozzles can be utilized in place of any conventional blasting nozzle with no modifications to, or upgrading of, standard blasting equipment required. Each nozzle consists of a wear resistant tungsten carbide liner protected by an external aluminum sleeve with industry standard 50mm (2" UNC) contractor threads.

All components of the PanBlast™ Soda Plus Contactor package are internally anodized and externally coated with a durable powder coating system for extended service life.



PanBlast™ Soda Plus Max Package -

Stock Code	Description	Weight
BAC-RC-0564-00	Soda Plus Max Package	12.80Kg (28.20lbs)

PanBlast™ Soda Plus Max Package Parts List -

Item	Stock Code	Description	Qty
1	BAC-RC-PB-0277	Tandem Valve 1 1/2" Assembly	1
2	BAC-VA-PB-0191	Corsa Valve II NPT 1 1/2" c/w Urethane Sleeve	1
3	BAC-RC-PB-0164	AirStop II Pneumatic NPT Handle Assembly	1
4	BAC-NZ-0514-00	Blast Nozzle AIN-8 Aluminum/Tungsten Induction	1

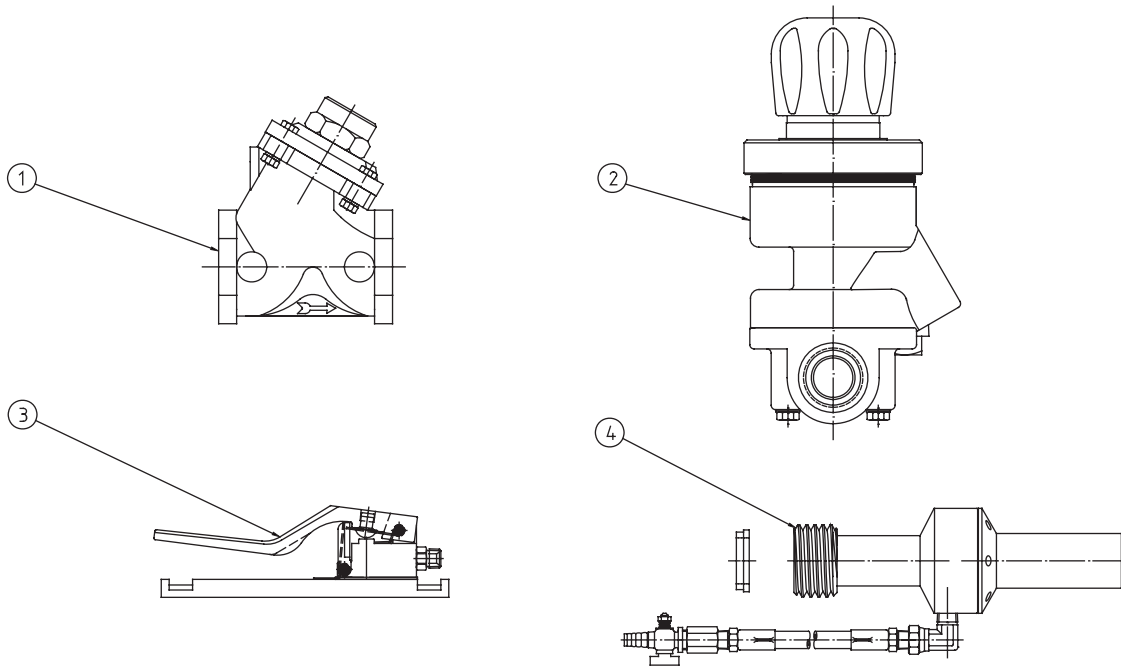

Blast Pots & Cabinets - Remote Control Valves - Abrasive Control Valves - Blast Nozzles - Nozzle Holders & Couplings - Helmets & Breathing Air Filters - Blast Suits