



PanBlast™ Helix 100 BSP Inlet Control Valve

*"Surface Preparation
Is Our Business"*

PanBlast™ Helix 100 BSP Inlet Control Valve

The PanBlast™ Helix 100 BSP Inlet Control Valve is a piston operated air control valve which is used to control the compressed supply into the blast pot and is designed to be used in conjunction with the Helix 50 BSP Exhaust Control Valve (or similar).

The PanBlast™ Helix 100 BSP Inlet Control Valve is designed to provide fast and effective operation. As soon as it receives a signal from the operators deadman control handle and both the valve itself, as well as all its parts, are fully compatible with the OEM RMS style valve.

Powder coated outer surfaces along with anodized internal parts, mean that the PanBlast™ Helix 100 Inlet Control Valve has a very high resistance to corrosion.

Featuring 32mm(1 1/4") ports, the PanBlast™ Helix 100 BSP Inlet Control Valve may also be combined with the PanBlast™ Helix 50 BSP Exhaust Control Valve, to create the Helix 150 BSP Remote Control Valve, which is a combined inlet and exhaust valve in the one compact assembly.

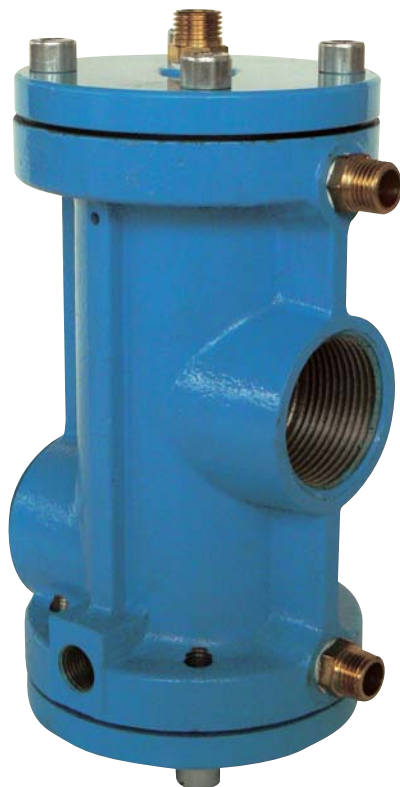

Helix 100 BSP Inlet Control Valve



Helix 150 BSP Combination Inlet
And Exhaust Valve

PanBlast™ Helix 100 BSP Inlet Control Valve Assembly -

Stock Code	Description	Weight
BAC-RC-PB-0305	Helix 100 BSP Inlet Valve	2.00kg (4.41lbs)

PanBlast™ Helix 100 BSP Inlet Control Valve Parts List -

Item	Stock Code	Description	Qty
1	YAC-PF-PB-0041	Hex Nipple	3
2	YAC-FN-PB-0278	Cap Head Machine Screw	8
3	YAC-RC-PB-0317	Housing Cap	2
4	YAC-RC-PB-0319	Cap Gasket	2
5	YAC-FN-PB-0280	Cap Head Machine Screw	1
6	YAC-RC-PB-0325	U Seal	1
7	YAC-RC-PB-0324	Piston	1
8	YAC-RC-PB-0322	Housing	1
9	YAC-BS-PB-0047	O-Ring	2
10	YAC-RC-PB-0320	Inlet Piston	1
11	YAC-PF-PB-0119	Hex Plug	1

PanBlast™ Helix 100 BSP Inlet Control Valve Service Kits -

Stock Code	Description
BAC-RC-0477-00	Helix 100 BSP Valve Seal Kit - Includes items 4, 6 & 9

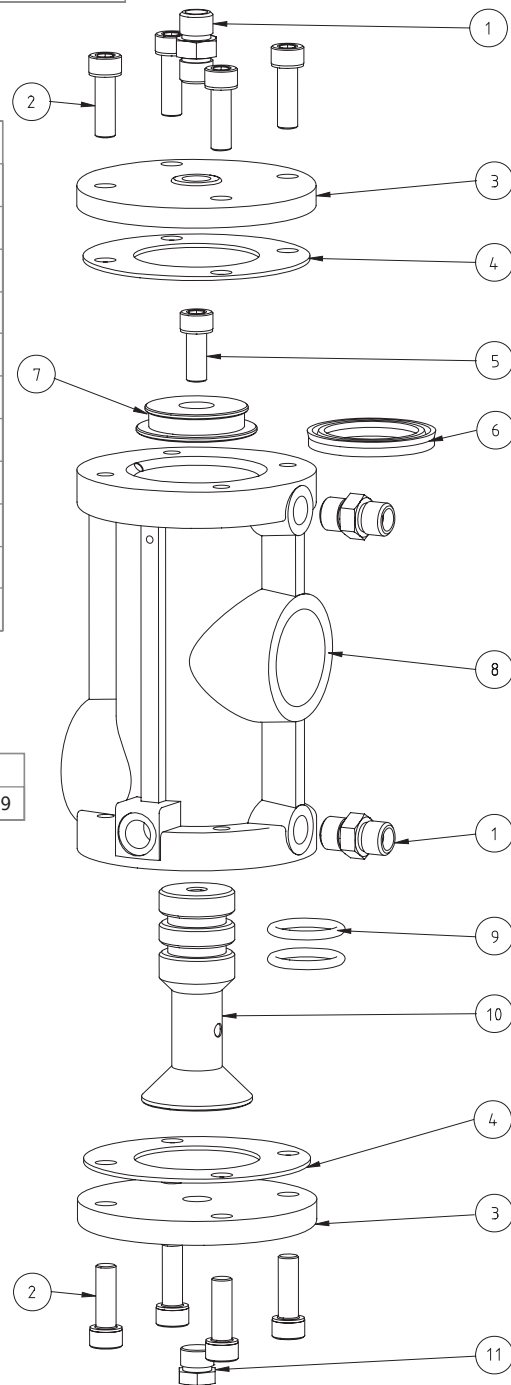

Blast Pots & Cabinets - Remote Control Valves - Abrasive Control Valves - Blast Nozzles - Nozzle Holders & Couplings - Helmets & Breathing Air Filters - Blast Suits